

# *MINI3562 Reference User Manual*

---

**V1. 20241202**

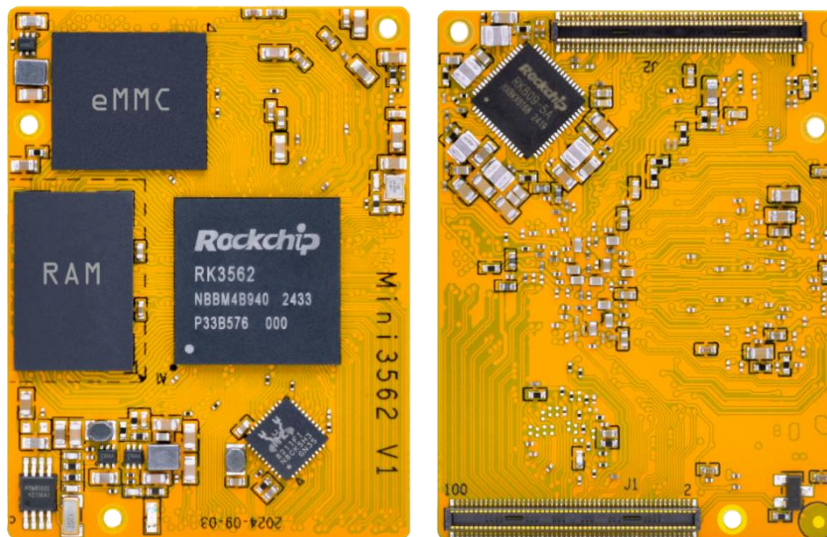

**Boardcon Embedded Design**

[www.armdesigner.com](http://www.armdesigner.com)

## 1. Introduction

### 1.1. About this Manual

This manual is intended to provide the user with an overview of the board and benefits, complete features specifications, and set up procedures. It contains important safety information as well.

### 1.2. Feedback and Update to this Manual

To help our customers make the most of our products, we are continually making additional and updated resources available on the Boardcon website ([www.boardcon.com](http://www.boardcon.com) , [www.armdesigner.com](http://www.armdesigner.com)).

These include manuals, application notes, programming examples, and updated software and hardware. Check in periodically to see what's new!

When we are prioritizing work on these updated resources, feedback from customers is the number one influence, If you have questions, comments, or concerns about your product or project, please no hesitate to contact us at [support@armdesigner.com](mailto:support@armdesigner.com).

### 1.3. Limited Warranty

Boardcon warrants this product to be free of defects in material and workmanship for a period of one year from date of buy. During this warranty period Boardcon will repair or replace the defective unit in accordance with the following process:

A copy of the original invoice must be included when returning the defective unit to Boardcon. This limited warranty does not cover damages resulting from lightning or other power surges, misuse, abuse, abnormal conditions of operation, or attempts to alter or modify the function of the product.

This warranty is limited to the repair or replacement of the defective unit. In no event shall Boardcon be liable or responsible for any loss or damages, including but not limited to any lost profits, incidental or consequential damages, loss of business, or anticipatory profits arising from the use or inability to use this product.

Repairs make after the expiration of the warranty period are subject to a repair charge and the cost of return shipping. Please contact Boardcon to arrange for any repair service and to obtain repair charge information.



## **Content**

1	MINI3562 Introduction.....	3
1.1	Summary .....	3
1.2	Features.....	3
1.3	MINI3562 Block Diagram .....	5
1.4	MINI3562 Specifications .....	6
1.5	MINI3562 PCB Dimension .....	7
1.6	Connector Type.....	7
1.7	MINI3562 Pin Definition .....	8
1.8	Development Board (EM3562).....	16
2	Hardware Design Guide.....	16
2.1	Peripheral Circuit Reference .....	16
3	Product Electrical Characteristics .....	20
3.1	Dissipation and Temperature .....	20
3.2	Reliability of Test.....	21

# 1 MINI3562 Introduction

## 1.1 Summary

The MINI3562 is a cost-optimized SOM powered by Rockchip RK3562 processor with quad-core Cortex-A53 CPU and ARM G52 2EE GPU, 1 TOPS NPU. This RK3562 SOM offers a smaller form factor and power efficiency for a wide range of target applications such as security surveillance and Traffic Management.

It is designed specifically for the high-performance devices such as TV box or recorder, VI devices, intelligent interactive devices, personal computers and robots. The high-performance multimedia processing and acceleration engine solution can help customers to introduce new technologies more quickly and enhance the overall solution efficiency.

## 1.2 Features

- **Microprocessor**
  - Quad-core 64-bit Cortex-A53 architecture, clocked at up to 2.0GHz.
  - Full implementation of the ARM architecture v8-A instruction set, ARM Neon Advanced SIMD (single instruction, multiple data) support for accelerated media and signal processing computation.
  - Integrated 32KB L1 instruction cache, 32KB L1 data cache with 4-way set associative.
- **Memory Organization**
  - LPDDR4 or LPDDR4X RAM up to 8GB
  - EMMC up to 128GB
- **Boot ROM**
  - Supports system code download through USB OTG
- **Secure system**
  - Embedded two cipher engine
  - Support key ladder to guarantee key secure
  - Support secure OS and data scrambling
  - Support OTP
- **Video Decoder/Encoder**
  - H.265 HEVC/MVC Main Profile yuv420@L5.0 up to 4096x2304@30fps.
  - H.264 AVC/MVC Main Profile yuv400/yuv420/yuv422/@L5.0 up to 1920x1080@60fps.
  - VP9 Profile0 yuv420@L5.0 up to 4096x2304@30fps.
  - H.264 High Profile level4.2, up to 1920x1080@60fps.
  - Support YUV/RGB video source with rotation and mirror.
- **NPU**
  - The built-in 1TOPS NPU supports hybrid operations with INT4/INT8/INT16/FP16 data types. Additionally, it boasts strong compatibility with a series of frameworks, such as TensorFlow, MXNet, PyTorch, and Caffe, enabling easy conversion of network models.
- **Display Subsystem**



**Support 1- channel MIPI\_DSI or LVDS**

- MIPI DSI TX (Up to 2048x1080@60Hz)
- LVDS(Up to 800x1280@60Hz)

**RGB video output interface**

- Support up to 2048x1080@60Hz
- Support RGB(up to 8bit) format
- Up to 150MHz data rate

**BT.656/BT.1120 video output interface**

- BT1120 up to 1080 P/I output
- BT656 up to 576 P/I output

• **MIPI CSI RX**

- Up to 4 data lanes, 2.5Gbps maximum data rate per lane.
- Support MIPI-HS, MIPI-LP mode.
- Support One interface with 1 clock lane and 4 data lanes.
- Support Two interface, each with 1 clock lane and 2 data lanes.

• **Audio**

**2- channel I2S interface**

- Support normal, left-justified, right-justified.
- Support master and slave mode.
- I2S, PCM and TDM mode cannot be used at the same time.

**1- channel SPDIF**

- Support two 16-bit audio data store together in one 32-bit wide location.
- Support biphasic format stereo audio data output.
- Support non-linear PCM transfer.

**2-channel digital DAC**

**Analog**

- 1- channel MIC IN.
- 1- channel Headphone.
- 1- channel Speaker OUT.

• **Multi-PHY Interface**

- Support multi-PHY with one PCIe2.1 and one USB3.0 controller
- USB 3.0 Dual-Role Device (DRD) Controller
- PCIe2.1 interface

• **USB 2.0 Host**

- Support one USB2.0 Host

• **Ethernet**

- On board RTL8211F
- Support RMII/RGMII PHY interface

• **I2C**

- Up to 5-CH I2C
- Support standard mode and fast mode(up to 400kbit/s)

• **1- channel SDIO and 1- channel SDRAM**

- Support SDIO 3.0 protocol
- Support SD3.0 card

- **SPI**
  - Up to 3 SPI controllers
  - Support two chip-select output
  - Support serial-master and serial-slave mode, software-configurable.
- **UART**
  - Support up to 10 UARTs
  - UART0 with 2 wires for debug
  - Embedded two 64byte FIFO
- **ADC**
  - Up to 11 ADC channels
  - 10-bit resolution up to 1MS/s sampling rate
  - SARADC0 for RECOVERY
  - Voltage input range between 0V to 1.8V
- **PWM**
  - Up to 15 PWMs with interrupt-based operation
  - Support 32bit time/counter facility
  - IR option on PWM3/PWM7/PWM11/PWM15
- **Power unit**
  - PMU RK809 on board
  - 3.4~ 5.5V Power input up to 4A current
  - 1.8V and 3.3V max 500mA output
  - Very low RTC consume current, less 0.25uA at 3V button Cell.

## 1.3 MINI3562 Block Diagram

### 1.3.1 RK3562 Block Diagram

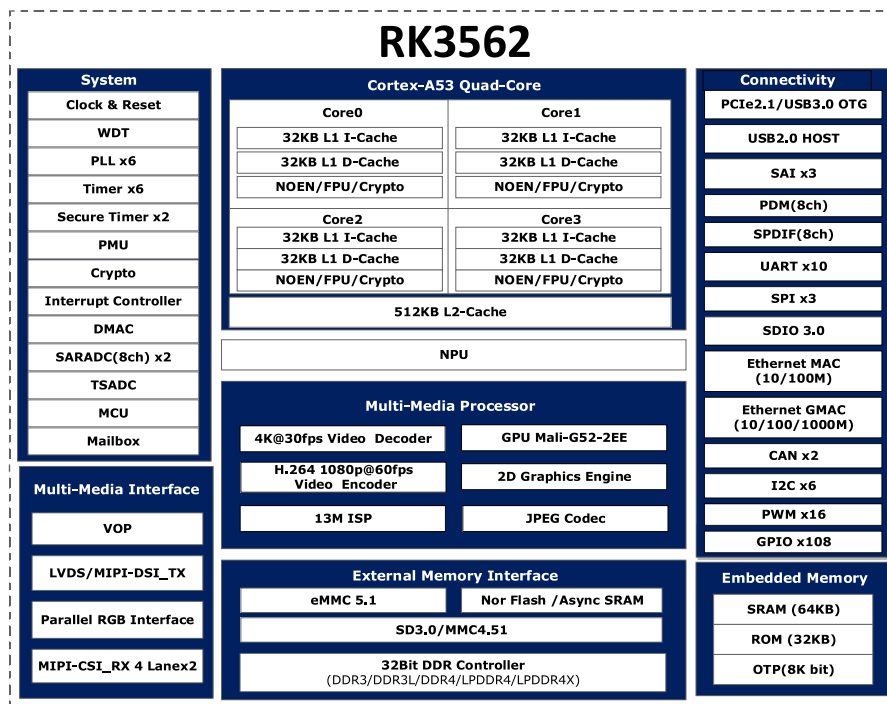



### 1.3.2 Development board (EM3562) Block Diagram

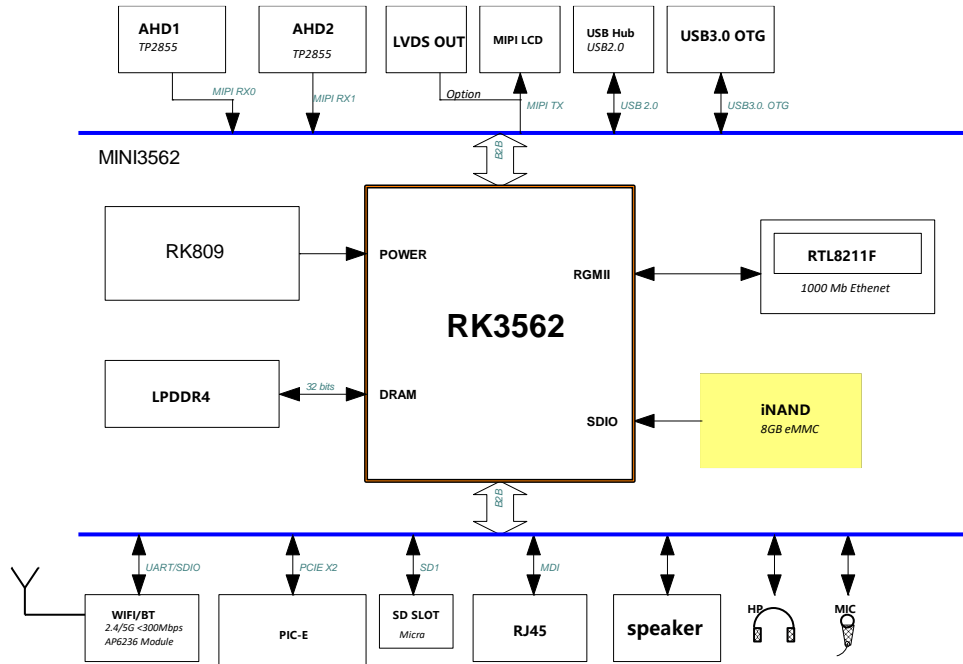

### 1.4 MINI3562 Specifications

Feature	Specifications
SoC	Rockchip RK3562. Quad-core Cortex-A53 up to 2.0GHz
GPU	ARM G52 2EE with support for OpenGL ES 1.1/2.0/3.2, OpenCL 2.0, Vulkan 1.1
NPU	1 TOPS
VPU	4K@30fps H.265 HEVC/MVC, VP9 Video Decoder 1080p@60fps H.264 AVC/MVC Video Decoder 1080p@60fps H.264 Video Encoder
Memory	4GB/8GB LPDDR4X
Storage	8GB/16GB/32GB/64GB/128GB
Supply Voltage	DC 5V
Pin out	5x UART, USB2.0 OTG, USB2.0 Host, MIPI DSI/LVDS, 2x MIPI CSI, GbE, PCIe2.1, 2x SDMMC, I2C, ADC, GPIO, I2S, PWM, etc
Ethernet	GbE PHY (RTL8211F) on core board
PCB Layer	8
Dimensions	45 x 34 mm
Weight	7.3 gram
Connectors	2x 100-pin, 0.4mm pitch Board-to-Board Connectors (Plug)
Application	security surveillance, Traffic Management, Retail Analytics, Manufacturing & Quality Control, etc.



## 1.5 MINI3562 PCB Dimension

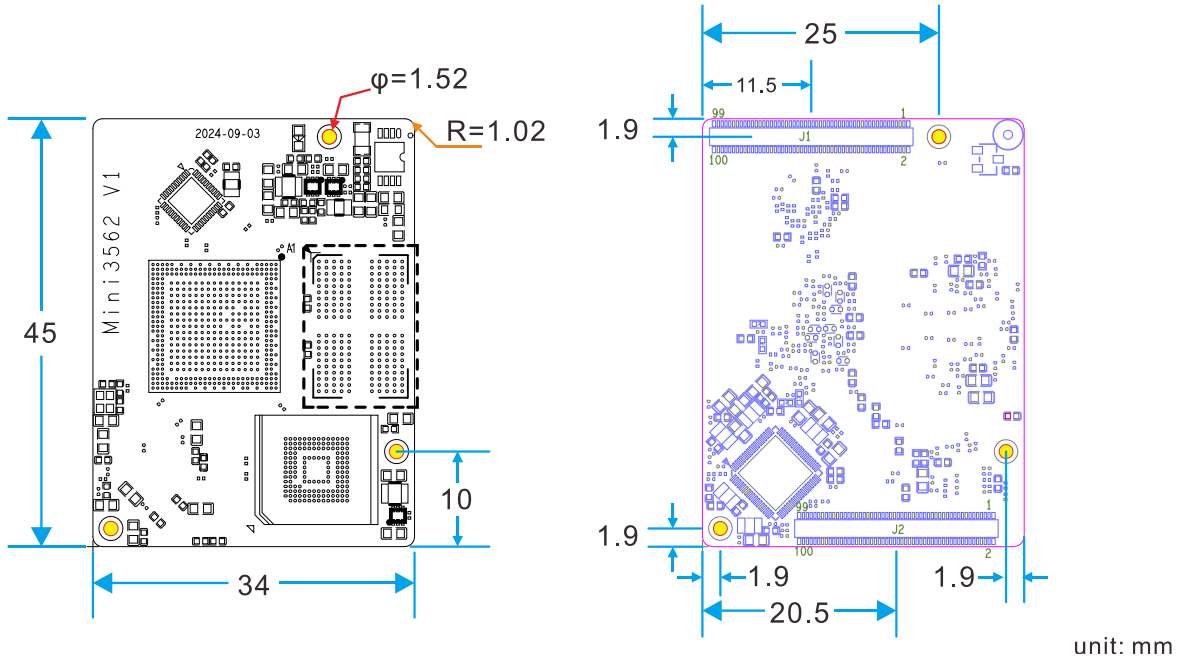

## 1.6 Connector Type

- Mini3562 connector

### Plug

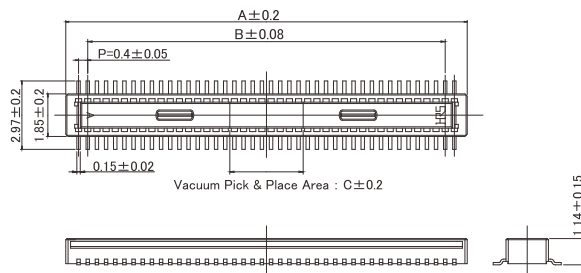
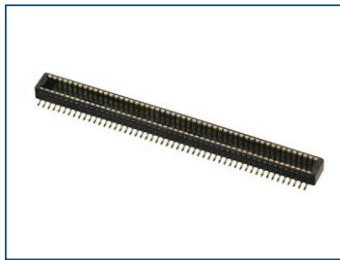

### Recommended PCB Pattern

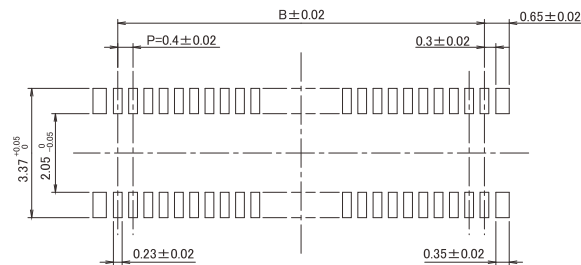

Unit : mm

Part No.	HRS No.	No. of Pos.	A	B	C	Purchase Unit (##):(51)	Purchase Unit (##):(58)
DF40C-100DP-0.4V(##)	CL0684-4032-1-##	100	21.52	19.6	3.2	○	○





• **Based board connector**

**Receptacle**

Stacking Height 1.5mm

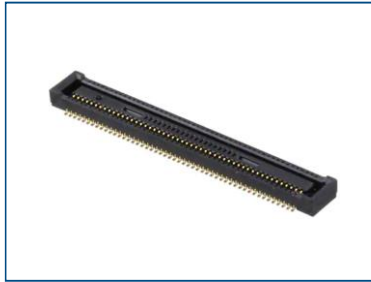

Recommended PCB Pattern

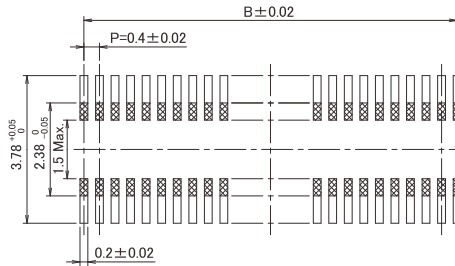
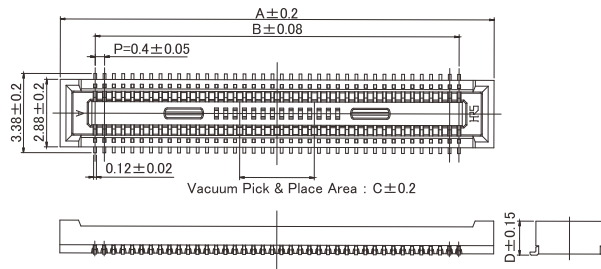

DF40C (No Retention Tab)

Unit : mm

Part No.	HRS No.	No. of Pos.	A	B	C	D	Purchase Unit (##):(51)	Purchase Unit (##):(58)
DF40C-100DS-0.4V(##)	CL0684-4033-4-##	100	22.6	19.6	3.2	1.45	○	○

## 1.7 MINI3562 Pin Definition

Pin (J1)	Signal	Description or functions	GPIO serial	IO Voltage(V)
1	VCC_RTC	POWER INPUT		1.8~3.3
2	GND			0
3	GND			0
4	RTCIC_32KOUT		(PU10K)	1.8
5	UART0_TX_M0_DEBUG	JTAG_CPU_MCU_TCK_M0	GPIO0_D1_u	3.3
6	GND			0
7	UART0_RX_M0_DEBUG	JTAG_CPU_MCU_TMS_M0	GPIO0_D0_u	3.3
8	CAM_RST1_L_1V8	I2S1_SDO0_M1/CAM_CLK3_OUT/UART8_RTSN_M0/SPI0_CLK_M1/PWM13_M1	GPIO3_B5_d	1.8
9	PCIE20_PERSTn_M1	PDM_SDI1_M0	GPIO3_B0_d	3.3
10	CAM_PDN1_L_1V8	I2S1_SDI0_M1/ISP_FLASH_TRIGIN/UART3_RTSN_M1	GPIO3_C1_d	1.8
11	PCIE20_WAKEn_M1	PDM_SDI2_M0/UART5_RX_M1	GPIO3_A7_d	3.3
12	CAM_RST0_L_1V8	I2S1_LRCK_M1/CAM_CLK2	GPIO3_B4_d	1.8



Pin (J1)	Signal	Description or functions	GPIO serial	IO Voltage(V)
		_OUT/UART8_CTSN_M0/SPI0_MOSI_M1/PWM12_M1		
13	PCIE20_CLKREQn_M1	PDM_CLK0_M0/UART5_TX_M1	GPIO3_A6_d	3.3
14	I2C5_SDA_M0_1V8	ISP_FLASH_TRIGOUT/UART9_RX_M	GPIO3_C3_d	1.8
15	TP_RST_L	SPI0_CSN1_M0/PWM4_M0/CPU_AVSPDIF_TX_M1	GPIO0_B7_d	3.3
16	I2C5_SCL_M0_1V8	ISP_PRELIGHT_TRIGOUT/UART9_TX_M1	GPIO3_C2_d	1.8
17	I2C2_SDA_TP	I2C2_SDA_M0/PCIE20_WAKEN_M0	GPIO0_B6_d	3.3
18	I2C4_SDA_M0_1V8	I2S1_SDO2_M1/I2S1_SDI2_M1/UART3_TX_M1/SPI0_CSN0_M1/I2C4_SDA_M0	GPIO3_B7_d	1.8
19	I2C2_SCL_TP	I2C2_SCL_M0/PCIE20_PERSISTN_M0	GPIO0_B5_d	3.3
20	I2C4_SCL_M0_1V8	I2S1_SDO1_M1/I2S1_SDI3_M1/UART3_CTSN_M1/SPI0_CSN1_M1/I2C4_SCL_M0	GPIO3_B6_d	1.8
21	TP_INT_L	UART2_RTSN_M0/PWM0_M0/SPI0_CLK_M0	GPIO0_C3_d	3.3
22	CAM_PDN0_L_1V8	I2S1_SDO3_M1/I2S1_SDI1_M1/UART3_RX_M1/SPI0_MISO_M1	GPIO3_C0_d	1.8
23	GND			0
24	GND			0
25	LCDC_HSYNC	I2S1_SDO1_M0/UART9_CTSN_M0/SPI2_CSN1_M0/I2C1_SCL_M1/UART3_TX_M0	GPIO4_B4_d	3.3
26	CAM_CLK1_OUT_1V8	I2S1_SCLK_M1/UART8_RX_M0	GPIO3_B3_d	1.8
27	LCDC_VSYNC	I2S1_SDO2_M0/UART9_RTSN_M0/SPI2_CSN0_M0/I2C1_SDA_M1/UART3_RX_M0	GPIO4_B5_d	3.3
28	GND			0
29	LCDC_DEN	I2S1_SDO3_M0/SPI2_CLK_M0/UART3_CTSN_M0	GPIO4_B6_d	3.3
30	CAM_CLK0_OUT_1V8	I2S1_MCLK_M1/UART8_TX_M0	GPIO3_B2_d	1.8
31	UART4_TX_M0/LCD_D7	I2S1_SDI0_M0	GPIO3_D0_d	3.3



Pin (J1)	Signal	Description or functions	GPIO serial	IO Voltage(V)
32	GND			0
33	UART7_RX_M0/LCD_D6	I2S1_SDO0_M0	GPIO3_C7_d	3.3
34	UART7_RTS_M0/LCD_D12	I2S1_SDI3_M0/SPI2_MOSI_M0/I2C2_SDA_M1	GPIO3_D3_d	3.3
35	UART4_RTS_M0/LCD_D5	I2S1_LRCK_M0/PWM15_M0	GPIO3_C6_d	3.3
36	UART7_CTS_M0/LCD_D11	I2S1_SDI2_M0/SPI2_MISO_M0/I2C2_SCL_M1	GPIO3_D2_d	3.3
37	UART4_CTS_M0/LCD_D4	I2S1_SCLK_M0/PWM14_M0	GPIO3_C5_d	3.3
38	UART4_RX_M0/LCD_D10	I2S1_SDI1_M0/UART3_RTSN_M0	GPIO3_D1_d	3.3
39	UART7_TX_M0/LCD_D3	I2S1_MCLK_M0	GPIO3_C4_d	3.3
40	GND			0
41	PHY0_LED1/CFG_LDO0/LCD_D21 (default: PHY0_LED1)	PWM12_M0/I2S2_LRCK_M1	GPIO4_A1_d	3.3
42	LCDC_CLK	PDM_CLK0_M1/CAM_CLK1_OUT_M1	GPIO4_B7_d	3.3
43	PHY0_LED2/CFG_LDO1/LCD_D9 (default: PHY0_LED2)	PDM_CLK0_M1/CAM_CLK1_OUT_M1	GPIO4_B7_d	3.3
44	GND			0
45	GND			0
46	PDM_SDI1/LCD_D16	UART1_CTSN_M1/PDM_SDI1_M1/UART6_RX_M1	GPIO4_B0_d	3.3
47	PHY0_MDI0+/LCD_D22 (default: PHY0_MDI0+)	SPI1_MOSI_M0/UART6_CTSN_M1	GPIO4_A2_d	3.3
48	GND			0
49	PHY0_MDI0-/LCD_D23 (default: PHY0_MDI0-)	SPI1_MISO_M0/UART6_RTSN_M1	GPIO4_A3_d	3.3
50	ETH_CLK_25M/LCD_D17 (default: ETH_CLK_25M)	PDM_CLK1_M1/CAM_CLK0_OUT_M1/I2S2_SCLK_M1	GPIO4_B1_d	3.3
51	PHY0_MDI1+/LCD_D13 (default: PHY0_MDI1+)	UART8_TX_M1/I2S2_SDI_M1	GPIO3_D4_d	3.3
52	LCD_D19	UART8_CTSN_M1/SPI1_CS_N0_M0	GPIO3_D7_d	3.3
53	PHY0_MDI1-/LCD_D14 (default: PHY0_MDI1-)	UART8_RX_M1/I2S2_SDO_M1	GPIO3_D5_d	3.3
54	LCD_D20	UART8_RTSN_M1/SPI1_CS_N1_M0	GPIO4_A0_d	3.3
55	PHY0_MDI2+/LCD_D18	UART9_RX_M0	GPIO4_B3_d	3.3



Pin (J1)	Signal	Description or functions	GPIO serial	IO Voltage(V)
	(default: PHY0_MDI2+)			
56	LCD_D15	SPI1_CLK_M0/I2S2_MCLK_M1	GPIO3_D6_d	3.3
57	PHY0_MDI2-/LCD_D2 (default: PHY0_MDI2-)	UART9_TX_M0	GPIO4_B2_d	3.3
58	GND			0
59	PHY0_MDI3+			
60	MIPI_CSI_RX1_CLK1P			INPUT
61	PHY0_MDI3-			
62	MIPI_CSI_RX1_CLK1N			INPUT
63	GND			0
64	MIPI_CSI_RX1_D3P			INPUT
65	MIPI_CSI_RX1_CLK0P			INPUT
66	MIPI_CSI_RX1_D3N			INPUT
67	MIPI_CSI_RX1_CLK0N			INPUT
68	MIPI_CSI_RX1_D2P			INPUT
69	MIPI_CSI_RX1_D1P			INPUT
70	MIPI_CSI_RX1_D2N			INPUT
71	MIPI_CSI_RX1_D1N			INPUT
72	GND			0
73	MIPI_CSI_RX1_D0P			INPUT
74	MIPI_CSI_RX0_CLK1P			INPUT
75	MIPI_CSI_RX1_D0N			INPUT
76	MIPI_CSI_RX0_CLK1N			INPUT
77	GND			0
78	MIPI_CSI_RX0_D3P			INPUT
79	MIPI_CSI_RX0_CLK0P			INPUT
80	MIPI_CSI_RX0_D3N			INPUT
81	MIPI_CSI_RX0_CLK0N			INPUT
82	MIPI_CSI_RX0_D2P			INPUT
83	MIPI_CSI_RX0_D1P			INPUT
84	MIPI_CSI_RX0_D2N			INPUT
85	MIPI_CSI_RX0_D1N			INPUT
86	GND			0
87	MIPI_CSI_RX0_D0P			INPUT
88	MIPI_DSI_TX_CLKP/LVDS_TX_CLKP			OUTPUT
89	MIPI_CSI_RX0_D0N			OUTPUT
90	MIPI_DSI_TX_CLKN/LVDS_TX_CLKN			OUTPUT
91	GND			0



Pin (J1)	Signal	Description or functions	GPIO serial	IO Voltage(V)
92	MIPI_DSI_TX_D1P/LVDS_TX_D1P			OUTPUT
93	MIPI_DSI_TX_D3P/LVDS_TX_D3P			OUTPUT
94	MIPI_DSI_TX_D1N/LVDS_TX_D1N			OUTPUT
95	MIPI_DSI_TX_D3N/LVDS_TX_D3N			OUTPUT
96	MIPI_DSI_TX_D0P/LVDS_TX_D0P			OUTPUT
97	MIPI_DSI_TX_D2P/LVDS_TX_D2P			OUTPUT
98	MIPI_DSI_TX_D0N/LVDS_TX_D0N			OUTPUT
99	MIPI_DSI_TX_D2N/LVDS_TX_D2N			OUTPUT
100	GND			0

Pin (J2)	Signal	Description or functions	GPIO serial	IO Voltage(V)
1	SARADC0_IN4			1.8
2	VCC3V3_SYS	POWER OUTPUT		3.3
3	SARADC0_IN4			1.8
4	VCC3V3_SYS	POWER OUTPUT		3.3
5	SARADC0_IN6			1.8
6	GND			0
7	SARADC0_IN7			1.8
8	PCIE_PWREN_H	I2C3_SDA_M0/UART2_RX_1/ SPDIF_TX_M0/UART5_RTSN_M1	GPIO3_A1_d	3.3
9	SARADC0_IN1_KEY/RECOVERY		(PU10K)	1.8
10	4G_DISABLE_L	I2C3_SCL_M0/UART2_TX_M1/PDM_SDI3_M0/UART5_CTSN_M1	GPIO3_A0_d	3.3
11	SARADC0_IN2			1.8
12	WIFI_WAKE_HOST_H	I2C1_SDA_M0	GPIO0_B4_d	3.3
13	GND			0
14	WIFI_REG_ON_H	I2C1_SCL_M0	GPIO0_B3_d	3.3
15	SARADC1_IN0			1.8



Pin (J2)	Signal	Description or functions	GPIO serial	IO Voltage(V)
16	HOST_WAKE_BT_H	UART6_RX_M0	GPIO0_C7_d	3.3
17	SARADC1_IN1			1.8
18	BT_WAKE_HOST_H	UART6_TX_M0	GPIO0_C6_d	3.3
19	SARADC1_IN2			1.8
20	BT_REG_ON_H	UART6_RTSN_M0/PWM2_M0 /SPI0_MISO_M0	GPIO0_C5_d	3.3
21	SARADC1_IN3			1.8
22	USBCC_INT_L	PCIE20_CLKREQN_M0	GPIO0_A6_d	3.3
23	SARADC1_IN5			1.8
24	HALL_INT_L	UART6_CTSN_M0/PWM1_M0 /SPI0_MOSI_M0	GPIO0_C4_d	3.3
25	GND			0
26	LCD_BL_PWM	UART2_CTSN_M0/PWM5_M0 /SPI0_CSN0_M0	GPIO0_C2_d	3.3
27	SDMMC0_CLK	TEST_CLK_OUT/UART5_TX_M0/ SPI1_CLK_M1	GPIO1_C0_d	3.3
28	LCD_RST_L	REF_CLK_OUT	GPIO0_A0_d	3.3
29	GND			0
30	LCD_PWREN_H	CLK_32K_IN/CLK0_32K_OUT /PCIE20_BUTTONRSTN	GPIO0_B0_d	3.3
31	SDMMC0_D3	JTAG_CPU_MCU_TMS_M1/ UART5_RTSN_M0/SPI1_CSN0_M1/ PWM11_M0/DSM_AUD_RN	GPIO1_B6_u	3.3
32	USB30_OTG0_VBUSDET			3.3
33	SDMMC0_D2	JTAG_CPU_MCU_TCK_M1/ UART5_CTSN_M0/SPI1_CSN1_M1/ PWM10_M0/DSM_AUD_RP	GPIO1_B5_u	3.3
34	SDMMC0_DET_L	I2C4_SDA_M1	GPIO0_A4_u	3.3
35	SDMMC0_D1	UART0_TX_M1/UART7_TX_M1/ SPI1_MISO_M1/DSM_AUD_LN	GPIO1_B4_u	3.3
36	GND			0
37	SDMMC0_D0	UART0_RX_M1/UART7_RX_M1/ SPI1_MOSI_M1/DSM_AUD_LP	GPIO1_B3_u	3.3
38	RMII_MDIO_1V8	I2C5_SDA_M1/ PWM3_M1	GPIO1_D0_d	1.8
39	SDMMC0_CMD	UART5_RX_M0/SPDIF_TX_M2	GPIO1_B7_u	3.3
40	RMII_MDC_1V8	I2C5_SCL_M1/ PWM2_M1	GPIO1_C7_d	1.8



Pin (J2)	Signal	Description or functions	GPIO serial	IO Voltage(V)
41	GND			0
42	GPIO2_A1_d_1V8	I2S2_MCLK_M0/ETH_CLK_2 5M_OUT_M1/I2S0_SDO3_M1 /SPI2_CLK_M1/CLK1_32K_O UT	GPIO2_A1_d	1.8
43	I2S2_LRCK/RMII_CRS_D V_1V8	UART4_TX_M1/SPI2_CSNO_ M1	GPIO1_D6_d	1.8
44	GND			0
45	I2S2_SDO/RMII_RXD1_1V 8	UART4_RTSN_M1/SPI2_MOS I_M1/PWM14_M1	GPIO1_D7_d	1.8
46	I2S2_SCLK/RMII_CLK_1V 8	UART4_RX_M1/SPI2_CSN1_ M1	GPIO1_D5_d	1.8
47	UART1_CTS/RMII_RXD0_ 1V8	PWM7_M1	GPIO1_D4_d	1.8
48	GND			0
49	I2S2_SDI/RMII_RXER_1V 8	UART4_CTSN_M1/SPI2_MIS O_M1/PWM15_M1	GPIO2_A0_d	1.8
50	USB30_OTG0_ID			
51	GND			0
52	UART1_TX/RMII_TXD1_1 V8	PWM5_M1	GPIO1_D2_d	1.8
53	SDIO_CLK/G_RCK_1V8	PWM1_M1	GPIO1_C6_d	1.8
54	UART1_RX/RMII_TXD0_1 V8	PWM4_M1	GPIO1_D1_d	1.8
55	SDIO_CMD/G_RD3_1V8	PWM0_M1	GPIO1_C5_d	1.8
56	UART1_RTS/RMII_TXEN_ 1V8	PWM6_M1	GPIO1_D3_d	1.8
57	SDIO_D3/G_RD2_1V8	PWM11_M1	GPIO1_C4_d	1.8
58	GND			0
59	SDIO_D2/G_TCK_1V8	PWM10_M1	GPIO1_C3_d	1.8
60	PCIE20_RXN	USB30_OTG0_SSRXN		
61	SDIO_D1/G_TD3_1V8	PWM9_M1	GPIO1_C2_d	1.8
62	PCIE20_RXP	USB30_OTG0_SSRXP		
63	SDIO_D0/G_TD2_1V8	PWM8_M1	GPIO1_C1_d	1.8
64	GND			0
65	GND			0
66	PCIE20_TXN	USB30_OTG0_SSTXN		
67	PCIE20_REFCLKP			
68	PCIE20_TXP	USB30_OTG0_SSTXP		
69	PCIE20_REFCLKN			
70	GND			0



Pin (J2)	Signal	Description or functions	GPIO serial	IO Voltage(V)
71	GND			0
72	USB20_HOST1_DP			
73	SPKP_OUT			OUTPUT
74	USB20_HOST1_DM			
75	SPKN_OUT			OUTPUT
76	USB30_OTG0_DP			
77	HPL_OUT			OUTPUT
78	USB30_OTG0_DM			
79	HP_SNS			0
80	VCC_1V8	POWER OUTPUT		1.8
81	HPR_OUT			OUTPUT
82	VDD_LDO9	POWER OUTPUT		0.6~3.4
83	GND			0
84	VCCSYS_SW1	POWER OUTPUT		5
85	MIC2_IN			INPUT
86	VCCSYS_SW1	POWER OUTPUT		5
87	MIC1_IN			INPUT
88	GND			0
89	GND			0
90	GND			0
91	RESETn		(PU10K)	1.8
92	PWEN		(PU10K)	5
93	PMIC_PWRON			5
94	VCC_SYS	POWER INPUT		5
95	VCC_SYS			5
96	VCC_SYS			5
97	VCC_SYS	POWER INPUT		5
98	VCC_SYS			5
99	VCC_SYS			5
100	VCC_SYS			5



## 1.8 Development Board (EM3562)

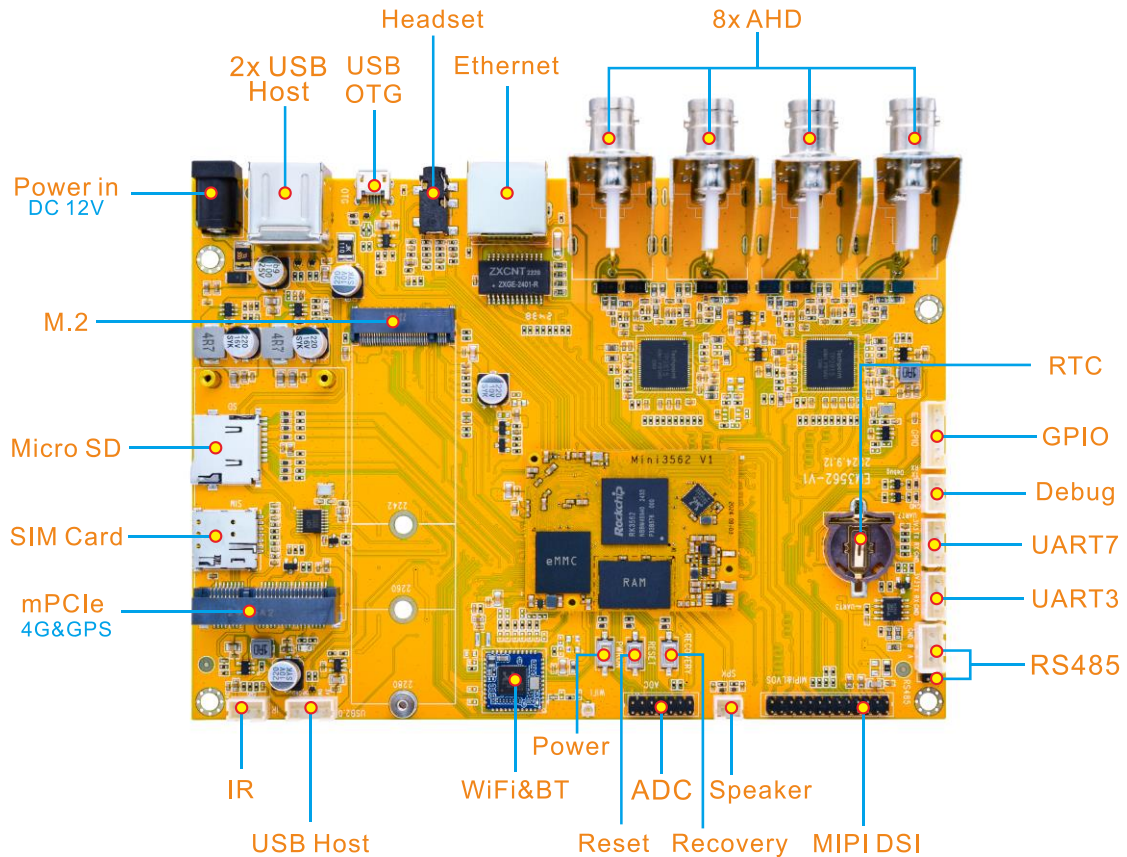

# 2 Hardware Design Guide

## 2.1 Peripheral Circuit Reference

### 2.1.1 External Power

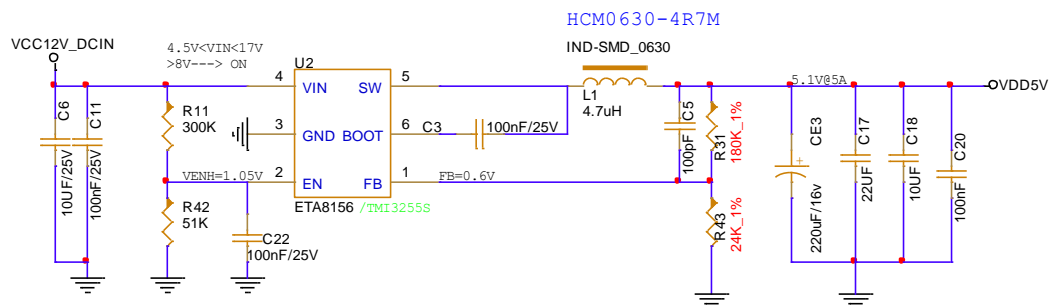

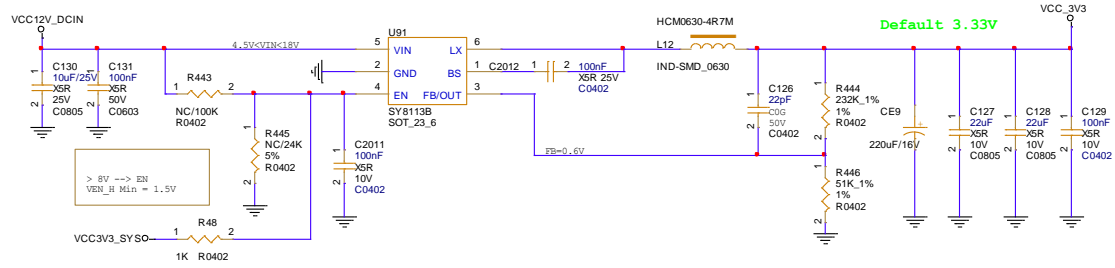

### 2.1.2 Debug Circuit

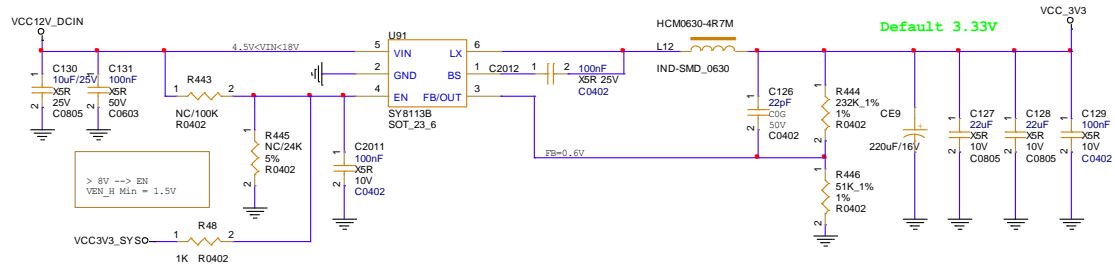

### 2.1.3 IR Circuit

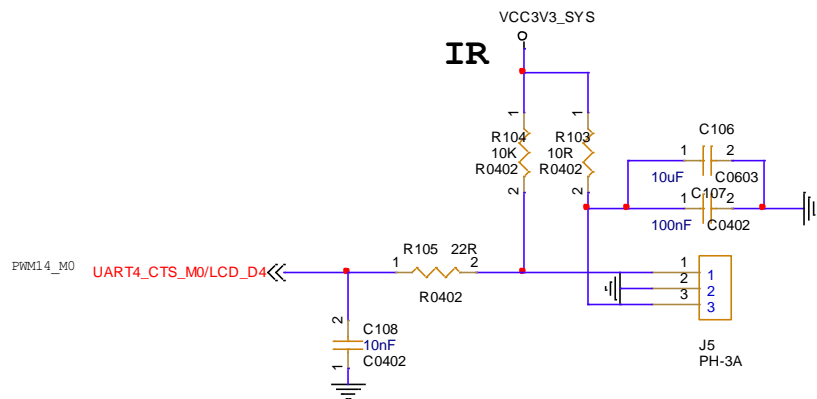

### 2.1.4 SD Circuit

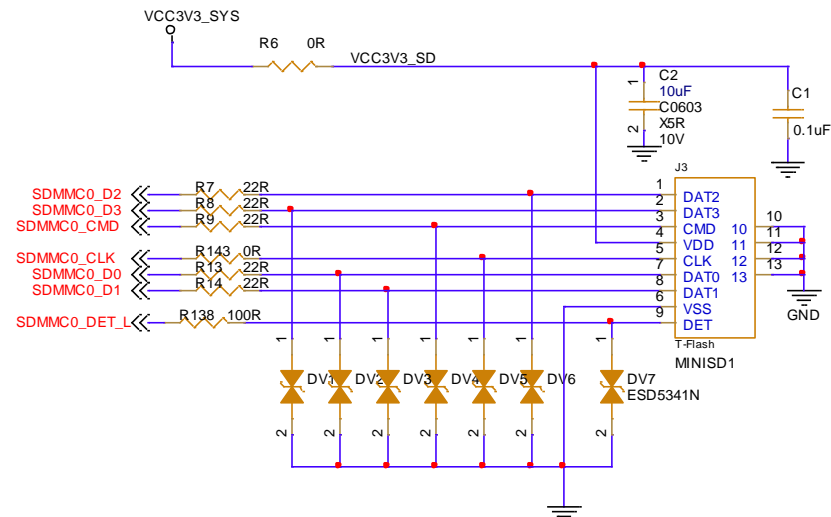





### 2.1.9 AHD Circuit

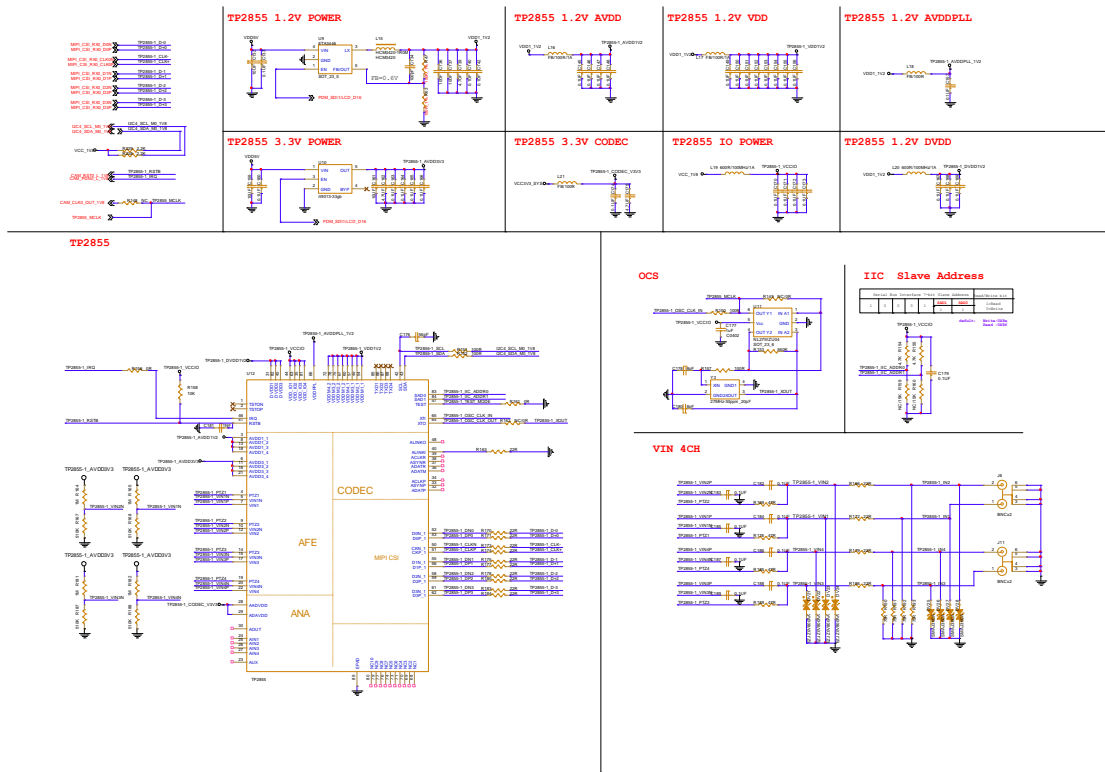

## 3 Product Electrical Characteristics

### 3.1 Dissipation and Temperature

Symbol	Parameter	Min	Typ	Max	Unit
VCC_SYS	System IO Voltage	3.4V	5	5.5	V
I <sub>sys_in</sub>	VCC_SYS input Current			3000	mA
VCC_RTC	RTC Voltage	1.8	3	3.4	V
I <sub>irtc</sub>	RTC input Current		0.25	8	uA
I <sub>3v3_out</sub>	VCC_3V3 output Current			500	mA



Symbol	Parameter	Min	Typ	Max	Unit
I1v8_out	VCC_1V8 output Current			500	mA
VCCSYS_SW1	output Current			1500	mA
VDD_LDO9	0.6V~3.4V output Current			400	mA
Ta	Operating Temperature	0		70	°C
Tstg	Storage Temperature	-40		85	°C

### 3.2 Reliability of Test

High Temperature Operating Test		
Contents	Operating 8h in high temperature	55°C±2°C
Result	TBD	

Operating Life Test		
Contents	Operating in room	120h
Result	TBD	